

# 5046.500-GA.C200A

X

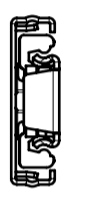

## CABINET MOUNTING HOLES

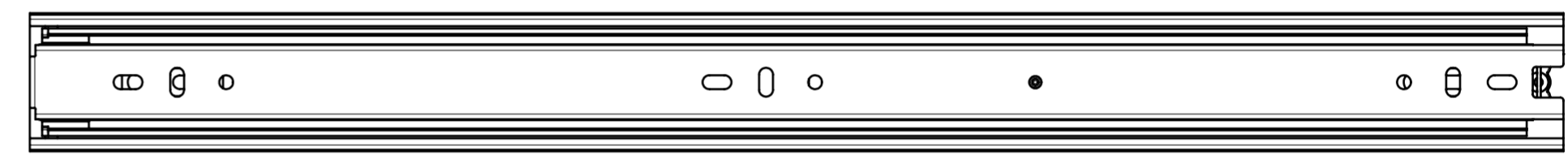
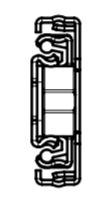
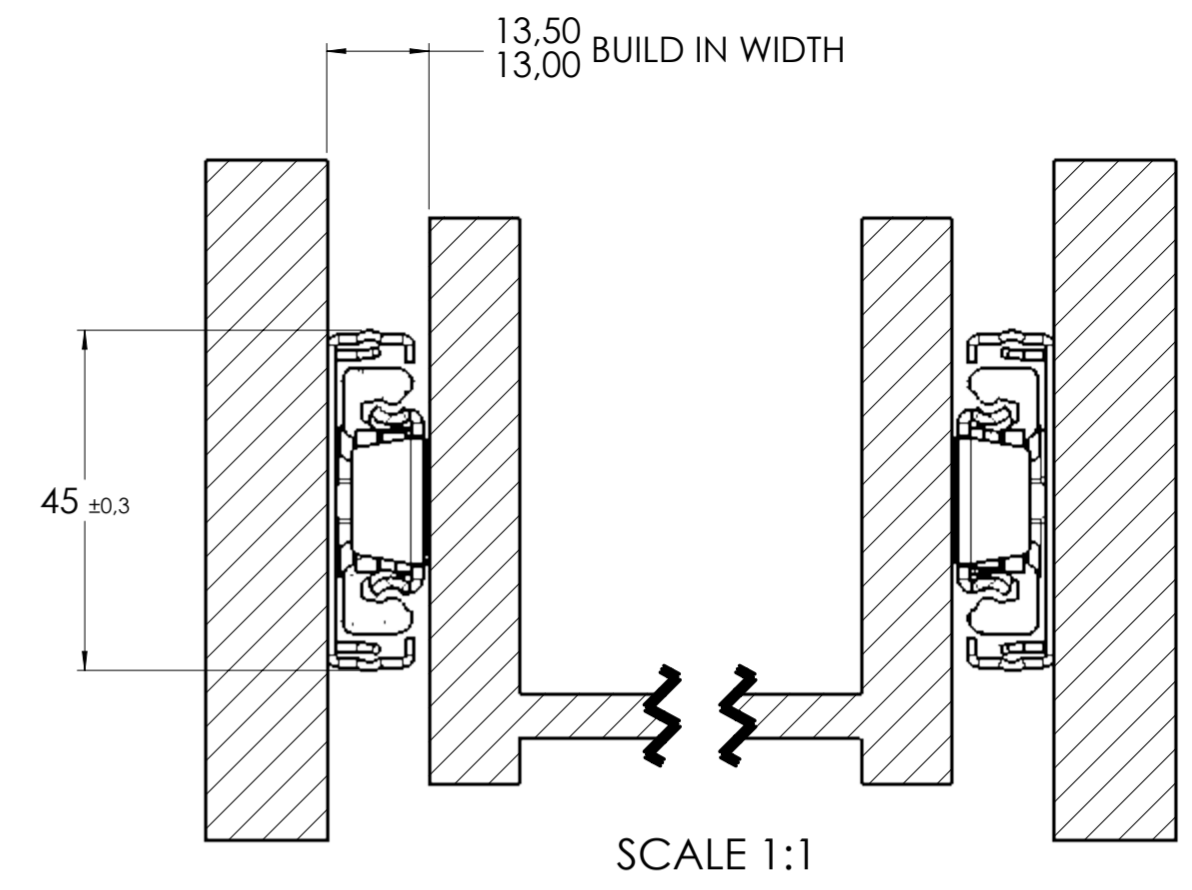
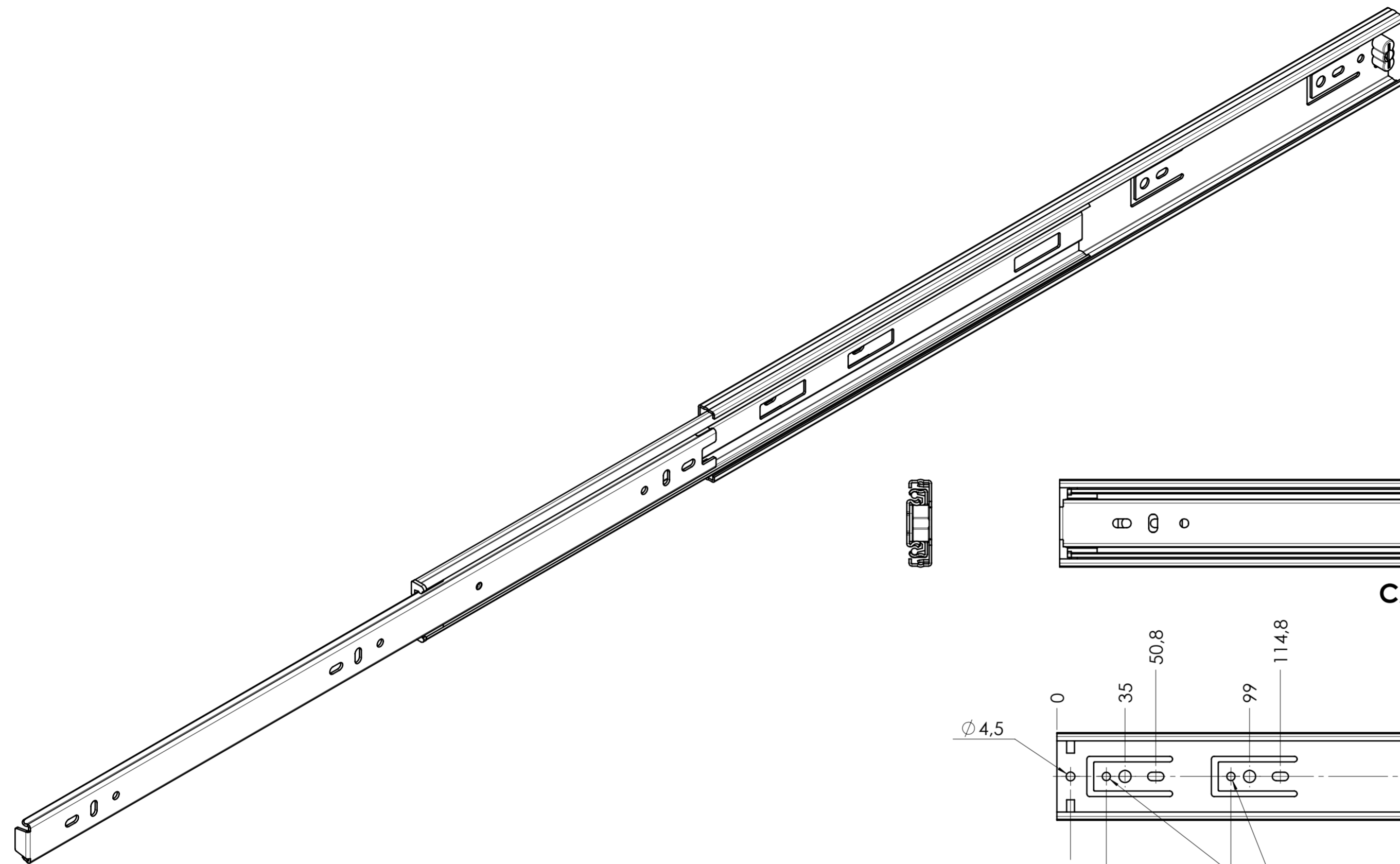
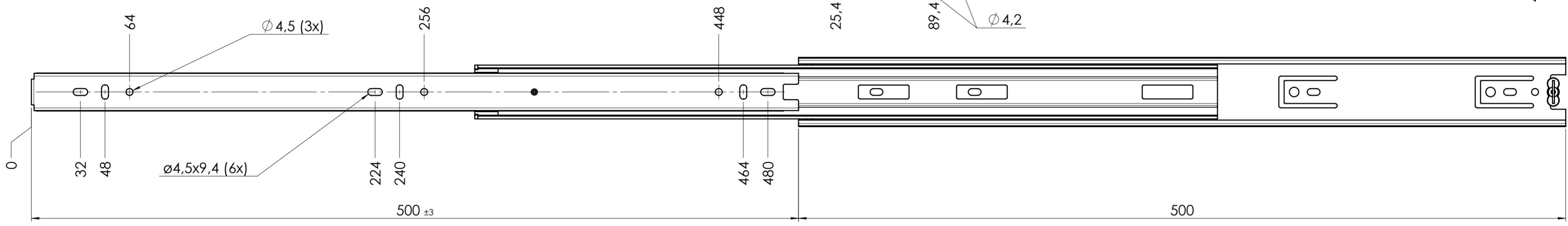
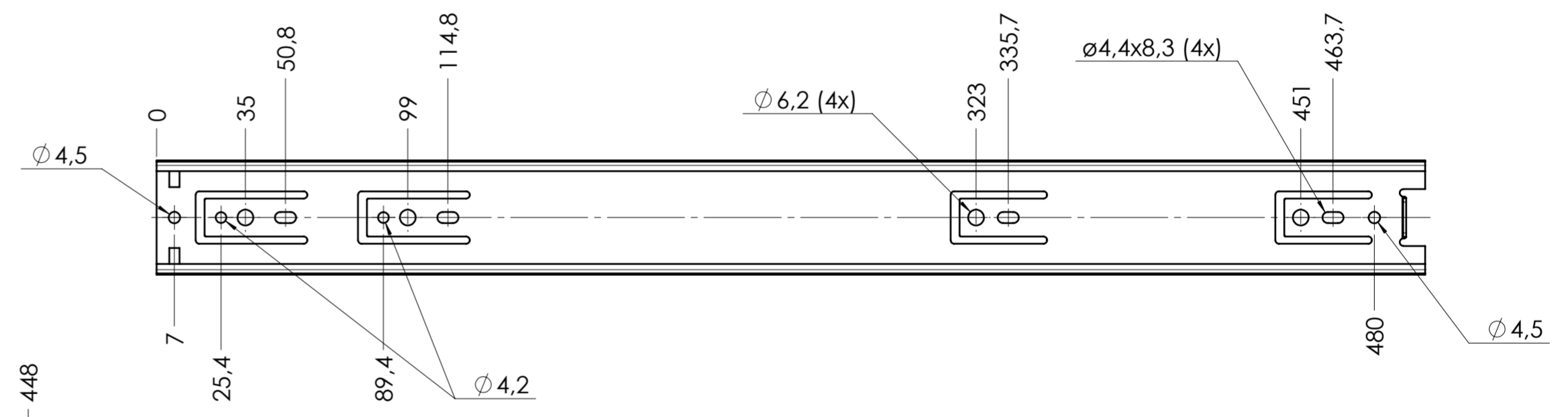

RECOMMENDED HARDWARE:  
 CABINET- 3.5mm SPAX M4 BUTTON HEAD OR #8 TRUSS HEAD SCREW  
 DRAWER- 3.5mm SPAX M4 BUTTON HEAD OR #8 TRUSS HEAD SCREW

general tolerances		DIN ISO 128-30	
stamping part according Fulterer W18-001	plastic part according DIN ISO 16742 TG4	missing dimensions see 3D = theor. intersection	
This drawing remains our property and may not be multiplied neither be disclosed to third parties (§§1,3 and 5 from the copyright Act (UrhG)) covered according to DIN ISO 16016			
(k)	scale:	1:2	surface:
(l)	date	12-05-2021	name
(m)	drawn	MW	
(n)	proven	00-00-0000	00
(o)	<b>Fulterer</b>		material, semi finished parts:
(p)			Steel
(q)			(technical requirements Fulterer)
(r)			description:
(s)			SIDE MOUNT FULL EXTENSION
(t)			DRAWER SLIDE WITH DRAWER
(u)			DISCONNECT
(v)			drawing number:
(w)			<b>5046.500-GA.C200A</b>
(x)			replaces version date:
(y)			
(z)			
ind.	changes	date	na.