

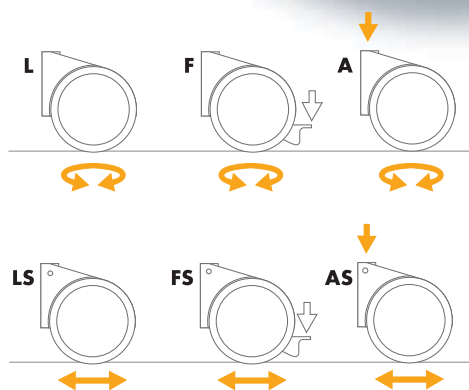

[®]
OTM



L libera

F freno a pedale

A freno automatico

S movimento unidirezionale

Supporti in lega di zama 15 pressofuso.
Ruote gemellate in nylon fibra di vetro al 20% condizionato. Battistrada in gomma termoplastica, antimacchia e antiusura, nera, grigia, o altri colori.
Dischetti laterali in nylon o ABS, colorati o finiture in legno. Perni in acciaio e specifici attacchi per i diversi impieghi. Freno in nylon stabilizzato.

Supports in die cast type 15 Zinc-Aluminium-Magnesium alloy.
Twin wheels made in nylon with 20% glass fibre. Wheels with tyre in stain-proof and wear-proof thermoplastic rubber, black, grey, or other colours. Side disks in nylon or ABS with series or optional finishes. Steel pivots and special attachments for different uses. Brake in stabilized nylon.

ROLL12

ARCH. FRANCO BIZZOZERO

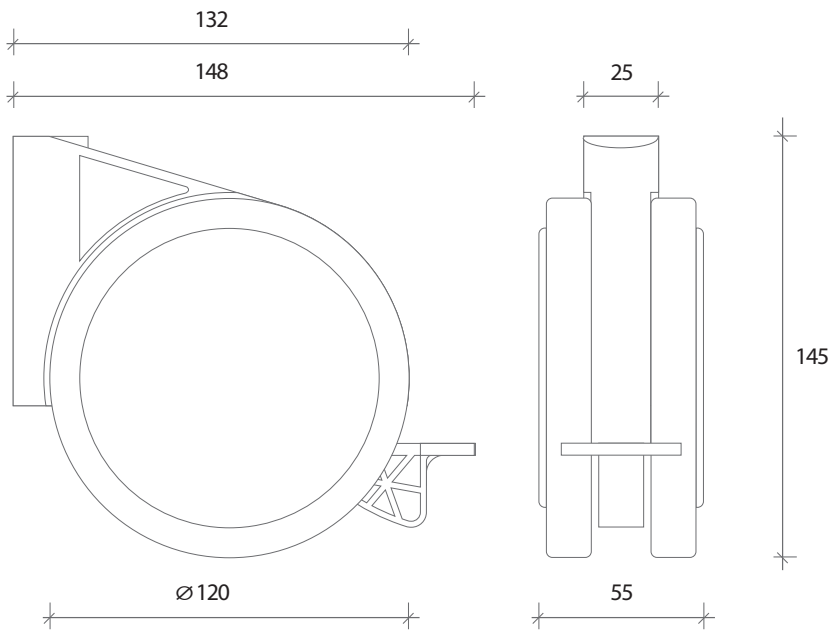

ROLL12
PATENT

Portata utile 120Kg.
Capacity 120Kg.



Dischetti Lateral - Side Disks

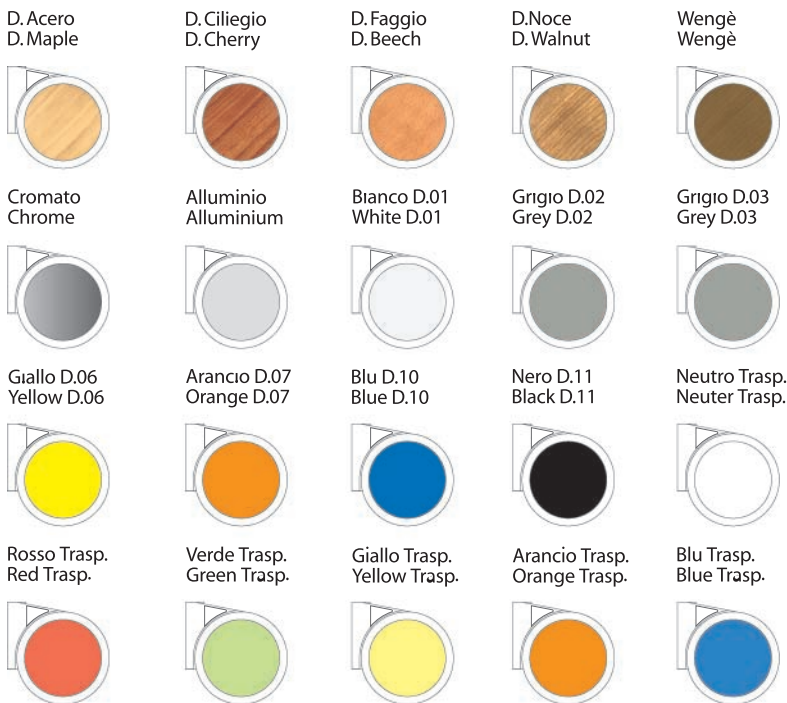

Gomme - Tyres



Supporti - Supports

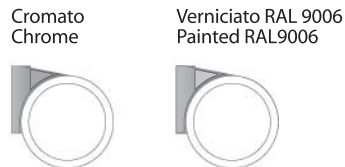

Indicazioni per il fissaggio - Fastening indications

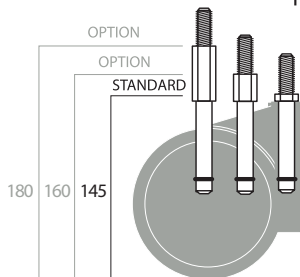

10 MA x 25
12 MA x 25

Perno filettato
Threaded pivot

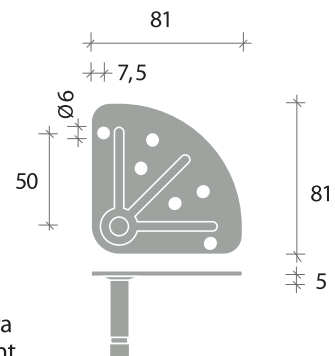

Attacco a piastra
Plate attachment