

NOVA PRO SCALA

Pot drawer H90 with rectangular railing and front support

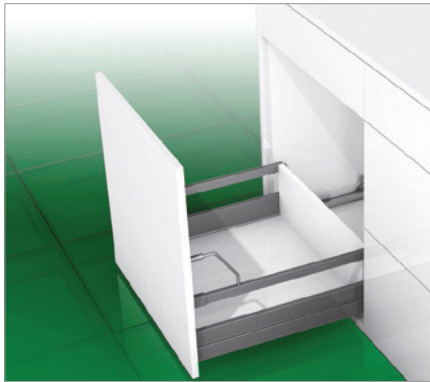

- Additional fixing points for optimum stability with extra-high fronts
- Flush-fitting back panel adapter
- Integrated height and side adjustment
- Tilt angle adjustment using railing and front support
- Optimum use of space due to straight in-side surfaces and low construction width
- Tool-free installation and removal of the front
- Width of bottom and back panel is the same
- Bottom panel machining not required

Packaging unit (PU):

- 123 = 100 items in PE
- 201 = 1 item in cardboard box (smallest PU = 10 units)
- 211 = 20 items in a cardboard box
- 228 = 150 items in a cardboard box
- 250 = 1500 items in a cardboard box
- 507 = 10 items in PE in a cardboard box
- 547 = 1000 items in PE in a cardboard box

ORDER INFORMATION

1 Nova Pro Scala drawer sides H90 Set: One left, one right



NL	Stone				Ice				Silver			
	Item No.	PU		Item No.	PU		Item No.	PU				
400	F100103117	201	211	F100103144	201	211	F100103171	201	211			
450	F100103120	201	211 228	F100103147	201	211 228	F100103174	201	211 228			
500	F100103123	201	211 228	F100103150	201	211 228	F100103177	201	211 228			
550	F100103126	201	211	F100103153	201	211	F100103180	201	211			
600	F100103129	201	211	F100103156	201	211	F100103183	201	211			
650	F100103132	201	211	F100103159	201	211	F100103186	201	211			

2 Rectangular railing with front support, screw-on, for wooden back panel Set: Railing, railing bracket (front/back) and cover cap, one of each left/right



NL	Stone				Ice				Silver			
	Item No.	PU		Item No.	PU		Item No.	PU				
400	F102103555	507		F102103564	507		F102103573	507				
450	F102103556	507		F102103565	507		F102103574	507				
500	F102103557	507		F102103566	507		F102103575	507				
550	F102103558	507		F102103567	507		F102103576	507				
600*	F102103559	507		F102103568	507		F102103577	507				
650*	F102103560	507		F102103569	507		F102103578	507				

* upon request

3 Installation hook Single item: Can be used on left/right



	Description	Item No.	PU	
32 mm	Expansion dowel	F102117719	123	547
50 mm	Expansion dowel	F102117720	123	547
32 mm	For press fitting	F102021854	123	250
50 mm	For press fitting	F102021153	123	250
	For screw fixing	F102021855	123	547

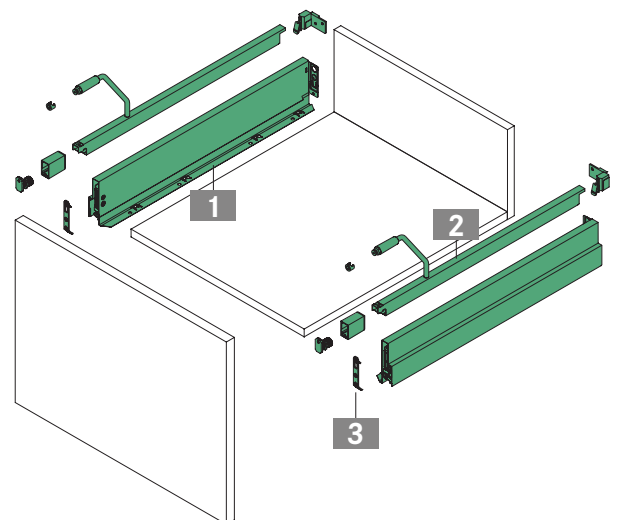

PAGE REFERENCES

Slides	32	Designer panels	60	Sensomatic	75
Inset panels	44	Accessories	62	Organising systems	97
Steel back panels	58	Technical information	68	Assembly technology	122

PLANNING DIMENSIONS

All dimensions in millimetres

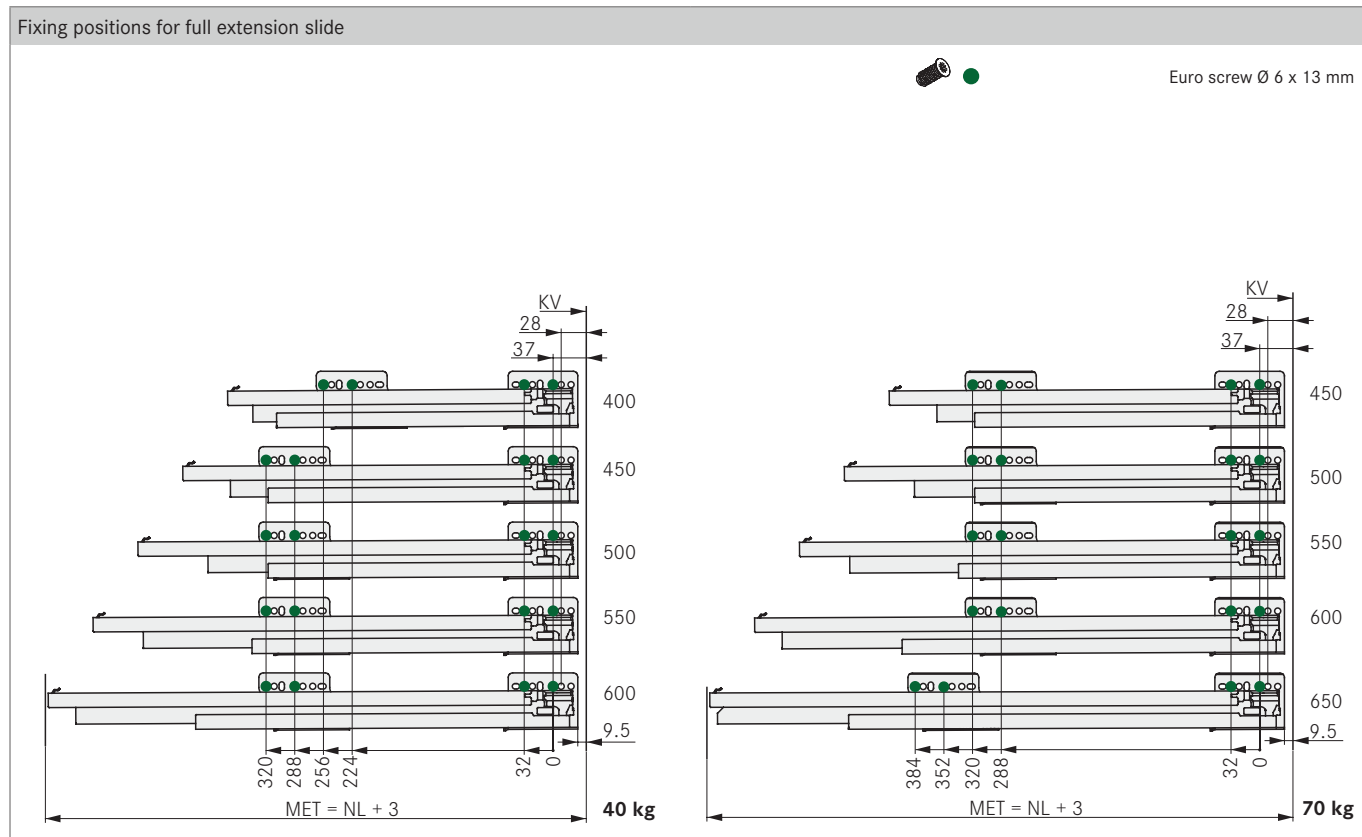
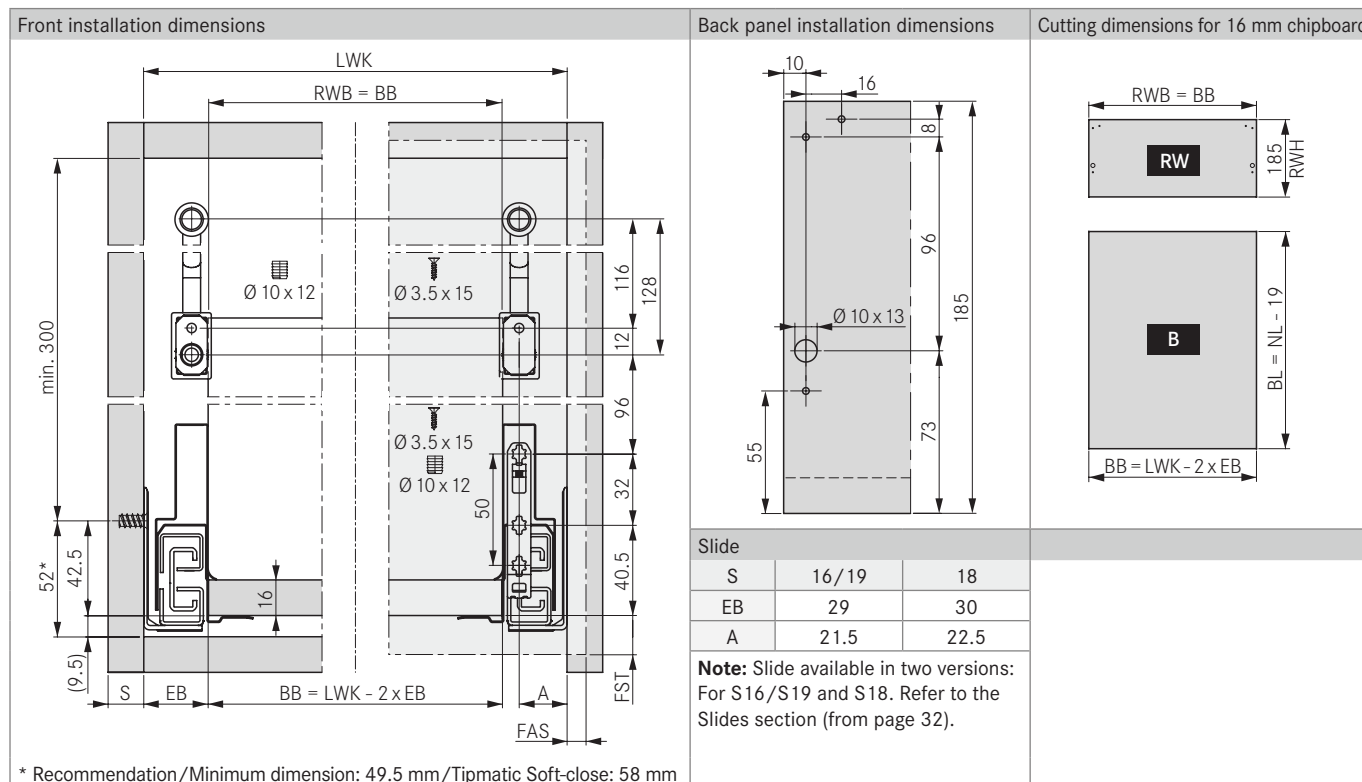

LEGEND

B	Bottom panel	FST	Front overlay	NL	Nominal length
BB / BL	Bottom width / Bottom length	KV	Front edge of cabinet	RW	Back panel
EB	Construction width	LWK	Inside cabinet width	RWB	Width of back panel
FAS	Front overlay, side	MET	Minimum installation depth	RWH	Height of back panel