

# Nexis Click-on

110°- hinge, standard door.

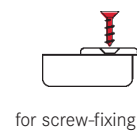

- Opening angle 110°
- Soft-close compatible
- With shallow cup depth (11 mm) also suitable for soft-formed doors
- Self-closing
- 3-dimensional adjustment with suitable mounting plate

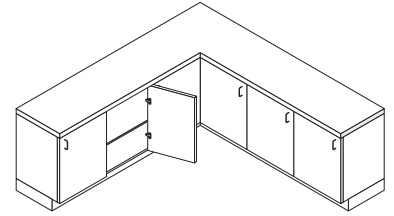

## Full overlay Cranking 00

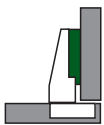

Cup hinge: steel, nickel-plated  
Hinge arm: steel, nickel-plated

Drilling pattern	Item No.	Item No.
48/9	146.322.53.0015	146.322.54.0015
42/11	138.322.73.0015	138.322.74.0015
	PU 250 pieces	PU 250 pieces

Cover caps for cranking 00	Item No.
*	Steel, nickel-plated, without imprint, Soft-close compatible 514.300.21.0215
**	Black plastic, without imprint, Soft-close compatible 514.000.22.9762 PU 1000 pieces

## Half overlay Cranking 08

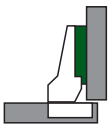

Cup hinge: steel, nickel-plated  
Hinge arm: steel, nickel-plated

Drilling pattern	Item No.	Item No.
48/9	146.322.53.0815	146.322.54.0815
42/11	138.322.73.0815	138.322.74.0815
	PU 250 pieces	PU 250 pieces

Cover caps for cranking 08	Item No.
*	Steel, nickel-plated, without imprint, Soft-close compatible 514.300.22.0015
**	Black plastic, without imprint, Soft-close compatible 514.000.22.9762 PU 1000 pieces

- \* \*\* on request with individual company logo
- \* \*\* on request with Grass imprint
- \* on request with Grass embossed

## Opening angle limiter



Limitation of opening angle to 85°  
Prevents doors from colliding with fronts or walls in corner installations.  
Black plastic

Item No.
641.000.10.0062
PU 1000 pieces

PU = packaging unit

Soft-close Click-on	Page 78	Mounting plates	Page 62	Assembly aids	Page 73
Cover cap for hinge cup	Page 72			Technical information	Page 88

Full overlay      Half overlay

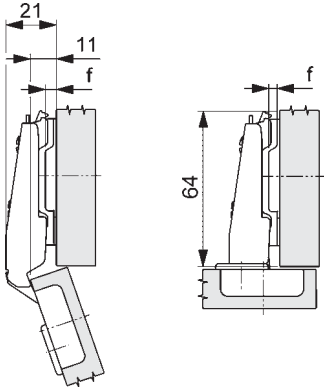

Drawings with mounting plate, height 02

Cup distance

Door overlay max.	Cup distance						
	3	4	5	6	7		
20					0		
19				0			
18			0		2		
17		0		2	3		
16	0		2	3	4		
15		2	3	4			
14	2	3	4				
13	3	4					
12	4						

Mounting plate height (f)

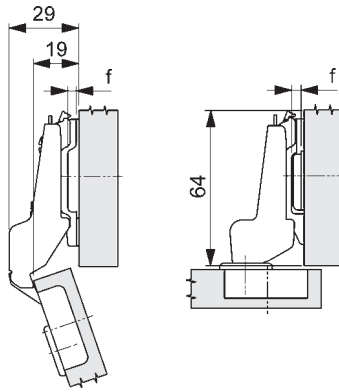

Drawings with mounting plate, height 02

Cup distance

Door overlay max.	Cup distance						
	3	4	5	6	7		
12					0		
11					0		
10			0		2		
9		0		2	3		
8	0		2	3	4		
7		2	3	4			
6	2	3	4				
5	3	4					
4	4						

Mounting plate height (f)

Table of minimum gaps      Reveal table

The minimum gap is the gap between the closed door and the front of the cabinet.

Door thickness	Cup distance				
	3	4	5	6	7
16	0.5	0.6	1.6	2.6	3.6
18	0.5	1.2	2.2	3.2	4.2
19	0.5	1.5	2.5	3.5	4.5
20	0.8	1.8	2.8	3.8	4.8
22	1.4	2.4	3.4	4.4	5.4

Minimum gap

Note

Reveal dimensions were determined with an edge radius (of the door) of 1 mm!

Hinge dimensions and calculation of reveal with factory setting.

We recommend a trial fitting.

Door thickness	Cup distance				
	3	4	5	6	7
16	0.5	0.5	0.5	0.5	0.5
18	1.0	1.0	1.0	1.0	1.0
19	1.2	1.2	1.2	1.2	1.2
20	2.2	1.5	1.5	1.5	1.5
22	4.7	3.7	2.8	2.1	2.1

Reveal min. (c)

Drilling patterns for screw-fixing version      Drilling patterns for press-fitting version      Cup dimensions

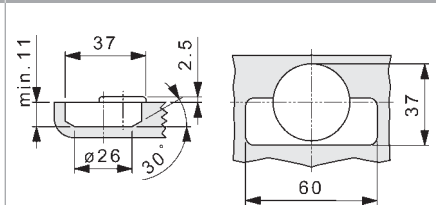
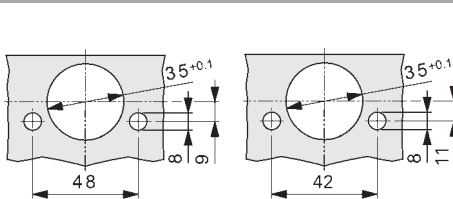
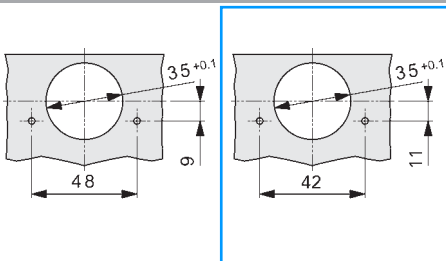

All dimensions in millimetres.