

System U-TOP

Montageanweisung Assembly instruction

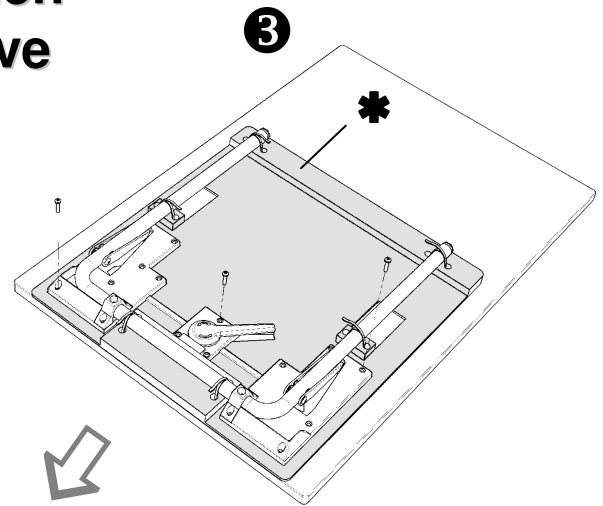

- *) Bohrschablone. Nicht entfernen
- *) Drilling pattern. Do not remove

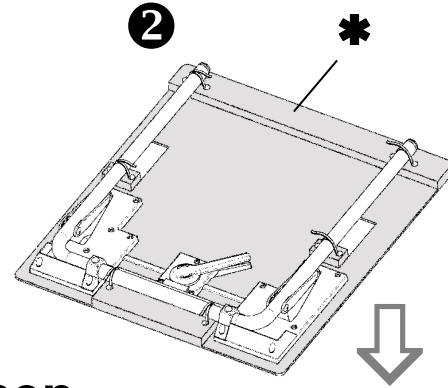
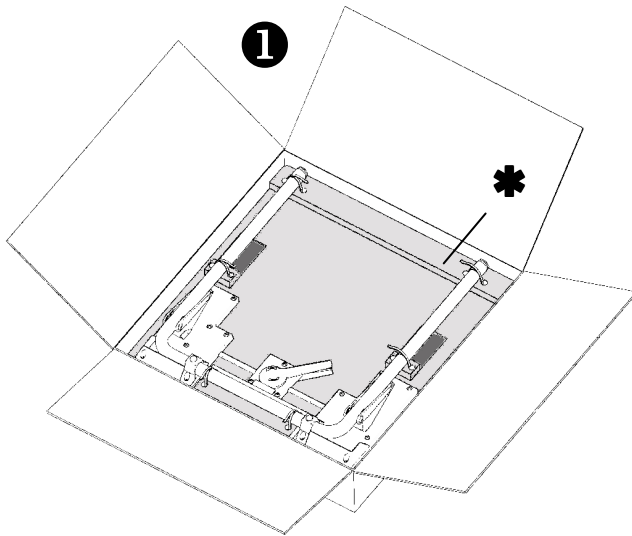
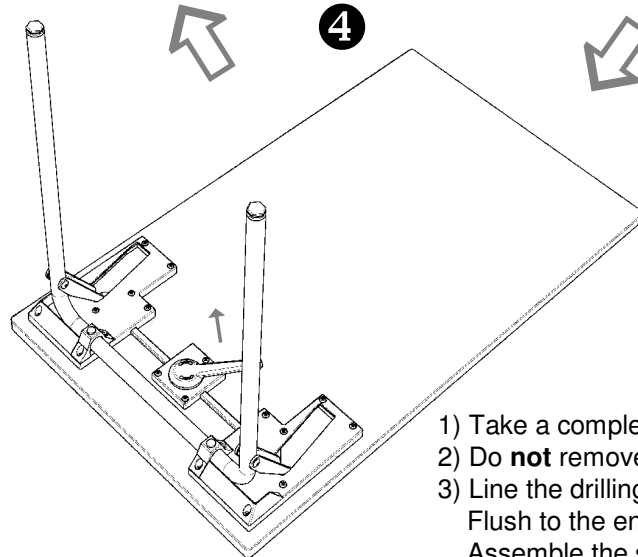
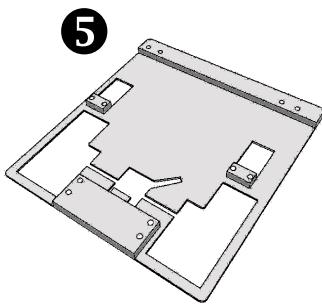

- 1) Ein komplettes Tischbein entnehmen.
- 2) Bohrschablone **nicht** entfernen
- 3) Bohrschablone auf der Tischplatte ausrichten.
Bündig zur Stirnseite, mittig zu den Seitenkanten.
Schrauben** montieren
- 4) Tischbein ausklappen. Restliche Schrauben** montieren.
- 5) Bohrschablone entfernen

- 1) Take a complete table leg.
- 2) Do **not** remove drilling pattern
- 3) Line the drilling pattern up on the tabletop.
Flush to the end edge, centric to the lateral edges.
Assemble the screws**
- 4) open the table leg. Assemble the remaining screws**.
- 5) Remove drilling pattern

**) Total 42 screws Spax pan head 6*35

**) Insgesamt 42 Schrauben Spax Rundkopf 6*35

