

**System: Laufschiene eingenutet, keine Nut im Boden, ohne Blende, mit Clip-Laufwerk (Finger-Justierrad), für 2 Holztüren bis 15 kg. Design Infront**

System: Top track, groove mounted, no groove in floor, with clip-on running gear (thumb-wheel height adjuster), for 2 wooden doors up to 15 kg. Design Infront

Système: Rail de roulement dans rainuré, aucune rainure dans le sol, sans cache, avec chariot de roulement à clipsage (molette d'ajustage), pour 2 portes en bois de 15 kg max. Design Infront

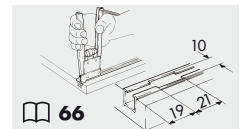
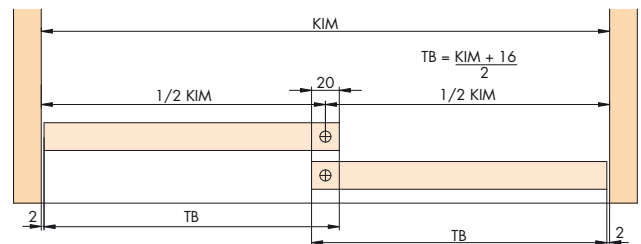
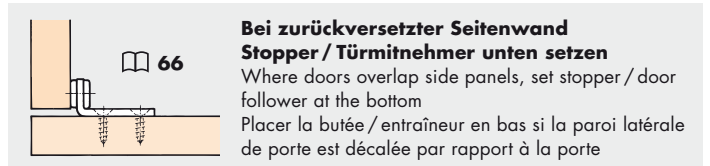
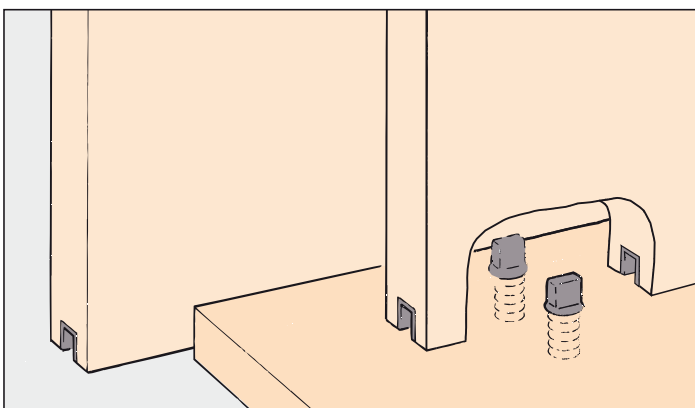

**Einbaubeispiele / Mounting examples / Exemples de montage**

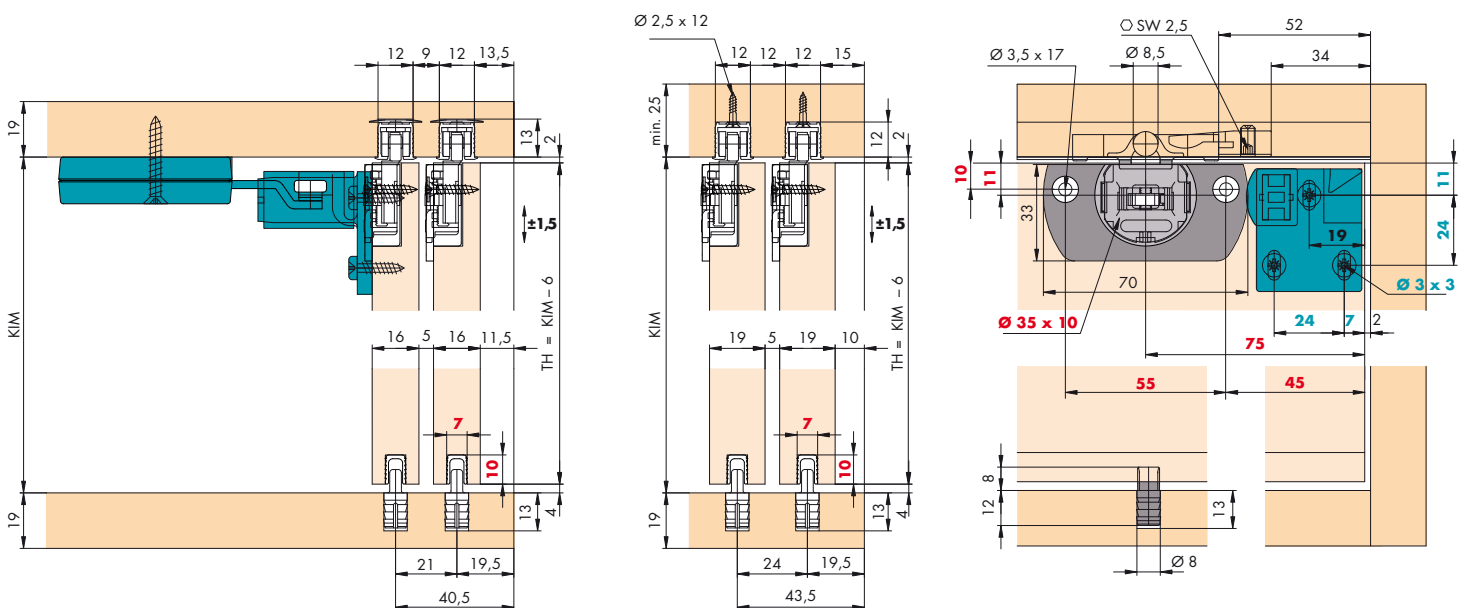

**Türbearbeitung = rote Zahlen / Door treatment = red numbers / Traitement de portes = numéros en rouge**  
**Dämpfung optional / Soft closing optional / Amortissement facultatif** **62/63**

**Befestigungsvarianten**

Mounting options  
Variantes de fixation

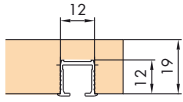

**A zum Verstemmen oder Kleben**  
for press-fitting or glueing  
à enfoncer ou coller

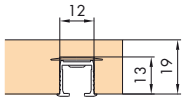

**B mit Drehriegel (nicht für Hartholz/MDF)**  
with swivel lug (not for hard wood/MDF)  
avec verrou (pas pour bois dur/MDF)

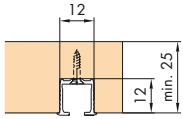

**C zum Schrauben**  
screwed on  
à visser

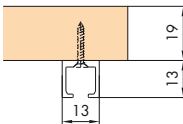







**D zum Aufschrauben**  
surface mounted  
à visser en applique

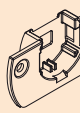

**Türgewichte**  
Panel weights  
Poids de portes **71**

**Garnituren / Sets / Garnitures**

<b>2</b> Türen Doors Portes		<b>No. 053.3115.071</b>	
 4x	 4x	 4x	 2x
 4x			

**Zubehör / Accessories / Accessoires**

**A° Einfachlaufschiene Alu, zum Verstemmen oder Kleben**

Single top track aluminium, for press-fitting or glueing  
Rail de roulement simple en alu, à enfoncer ou coller

Gr./Size	Art. No.
2500 mm	053.3007.250
3500 mm	053.3007.350
6000 mm	053.3007.600

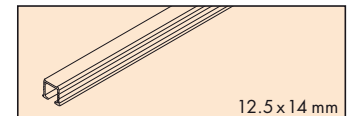

**B° Einfachlaufschiene Alu, mit Drehriegel (nicht für Hartholz/MDF)**

Single top track aluminium, with swivel lug (not for hard wood/MDF)  
Rail de roulement simple en alu, avec verrou (pas pour bois dur/MDF)

2500 mm**	053.3008.250
3500 mm**	053.3008.350
6000 mm	053.3008.600

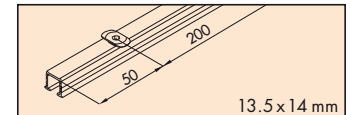

**C° Einfachlaufschiene Alu, gelocht, zum Schrauben**

Single top track aluminium, pre-drilled, screwed on  
Rail de roulement simple en alu, perforé, à visser

2500 mm**	053.3009.250
3500 mm**	053.3009.350
6000 mm	053.3009.600

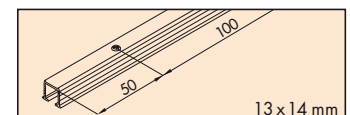

**D Einfachlaufschiene Alu eloxiert, gelocht, zum Aufschrauben**

Single top track aluminium anodized, pre-drilled, surface mounted  
Rail de roulement simple en alu anodisé, perforé, à visser en applique

2500 mm	053.3035.250
3500 mm	053.3035.350
6000 mm	053.3035.600

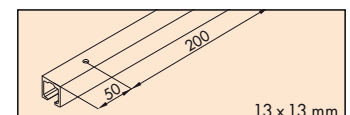

**Führungsschiene, Kunststoff anthrazit, 7 mm**

Guide track, plastic anthracite, 7 mm  
Rail de guidage, plastique anthracite, 7 mm

2500 mm	053.3012.250
3500 mm	053.3012.350
6000 mm	053.3012.600

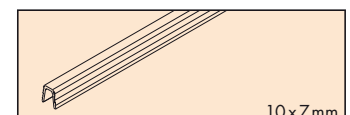

**Einfachlaufschiene Alu, gelocht, gebogen, zum Schrauben**

Single top track aluminium, pre-drilled, curved, screwed on  
Rail de roulement simple en alu, perforé, cintré, à visser

R = 500 mm	053.3102.001
R = 750 mm	053.3102.002
R = 1000 mm	053.3102.009

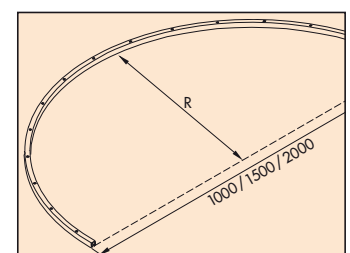

\*\* beidseitig ausgeklinkt / notched on both ends / encoché des deux côtés

° ab Radius > 1600 mm von Hand biegsam / can be manually bent from a radius > 1600 mm / à partir d'un rayon > 1600 mm cintrage manuel

**Sonderzubehör / Special accessories / Accessoires spéciaux:** ☞ 66