

KINVARO

T-Slim lift-up flap fitting for fronts made from wood (inset)



- Flush inset flap fitting for high design requirements and maximum storage space
- Milling depth: cabinet side: 12.2 mm, front: 13.7 mm
- Low opening forces and multi-position stop
- Convenient adjustment of the spring force
- Fast, tool-free clip fitting of the front
- Flap with 3-dimensional adjustment of height ± 2.5 mm, side ± 2.0 mm, depth $+3.0$ mm / -1.0 mm
- 107 degrees opening angle
- Integrated, opening angle reduction clip with optional activation (75°)
- Three different power factors
- Can be used for flaps made from wood
- Cover caps and adapters in Stone, Ice and Silver (all cover caps can be painted)

Available in two versions:

- With integrated damping (Soft-close, damper can be switched on/off)
- With integrated automatic opening system (Tipmatic Plus)

ORDER INFORMATION

Kinvaro T-Slim set for flaps made from wood

Set: Fitting (1x left/1x right), front connection (1x left/1x right), cover cap (3x left/3x right), screws (12x)

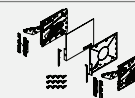

Power factor (LF)	Soft-close			Tipmatic Plus		
	Stone	Ice	Silver	Stone	Ice	Silver
250 - 550	F151149002	F151149004	F151149003	F151149011	F151149013	F151149012
500 - 1100	F151149005	F151149007	F151149006	F151149014	F151149016	F151149015
1000 - 2250	F151149008	F151149010	F151149009	F151149017	F151149019	F151149018

Power factor (LF) = flap height (mm) x (flap weight (kg) + 2 x handle weight (kg))
Cover caps can be painted

Tipmatic Pin see page 60



Kinvaro-T-Slim set consisting of:

- 1 Fitting left and right (1x)
 - 2 Front connection left and right (1x)
 - 3 Cover caps left and right (3x)
 - 4 Screws (12x)
- Installation instructions (1x)

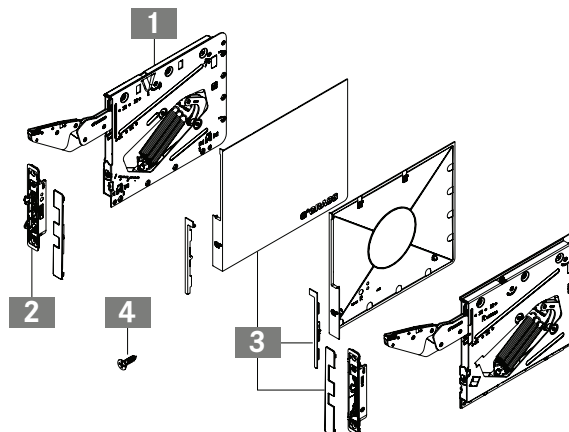

Assembly aids	78
Kinvaro T-Slim adjustment options	62

Individual components	32
-----------------------	----

--	--

